

## Models 246 & 247 Light Duty Monitor Bells

### Features

- Powerful solenoid type mechanisms
- Heavy pressed steel construction
- Made in U.S.A.

### Description

Vibrating Monitor Bells – Compact underdome bells designed for light duty signaling applications such as stores, offices, schools, hospitals and light manufacturing facilities. Available in either 3" or 4" sizes. These bells are provided for both AC and DC vibrating operation. Single stroke version available in AC only.

### Mechanism

Powerful solenoid type mechanisms designed to provide a maximum striking action on a minimum of current consumption.

### Insulation

Units are amply protected against voltage spurts. Will withstand up to 1500 volts RMS for a minute between current carrying parts and base.

### Contact Points

(On DC Models only). Extra large size. Fashioned from finest coin silver.

### Contact Springs

(On DC Models only). Formed phosphor bronze. Assures good contact point pressure.

### Material

Frames and covers of heavy pressed steel gongs of specially cold-pressed gong steel.



**3" Monitoring Bell**

### Finish

Protective gray enamel.

### Coil

Sufficiently wound to result in only a modest temperature increase when operated continuously. Fully Insulated.

### Shipping Weight

246-3, 247-3, 336-3	3/4 lbs.
246-4, 247-4	1-1/4 lbs.

## Dimensions

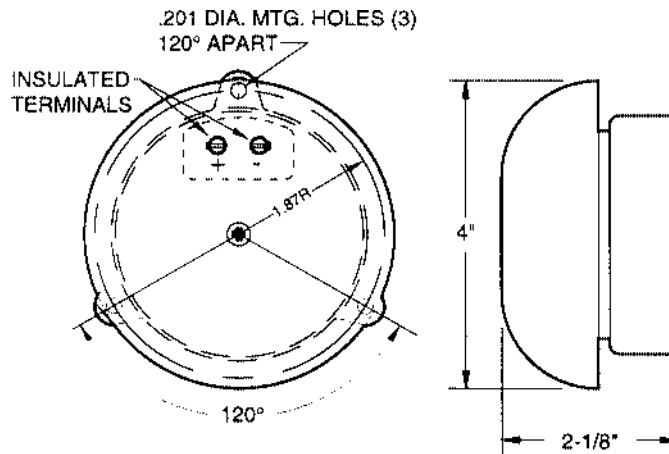

**Detail: Model 2464012060**

## Ordering Information

Model	Description	Voltage	Amps	Part No.
2463012060	Monitoring Bell Vibrating, 3" gong	120 VAC	0.07	500-648346FA
2464012060	Monitoring Bell Vibrating, 4" gong	120 VAC	0.07	500-648431FA
2473012DC	Monitoring Bell Vibrating, 3" gong	12 VDC	0.5	500-648347FA
2473024DC	Monitoring Bell Vibrating, 3" gong	24 VDC	0.25	500-648348FA
2473032DC	Monitoring Bell Vibrating, 3" gong	32 VDC	0.19	500-648349FA
2473075DC	Monitoring Bell Vibrating, 3" gong	72 VDC	0.09	500-648350FA
2473312DC	Monitoring Bell Vibrating, Black 3" gong	12 VDC	0.5	500-648352FA
2474012DC	Monitoring Bell Vibrating, 4" gong	12 VDC	0.5	500-648432FA
3363012060	Monitoring Bell Single Stroke, 3" gong	120 AC	0.07	500-648351FA



Siemens Building Technologies, Inc.  
 8 Fernwood Road • Florham Park, NJ 07932  
 Tel: (973) 593-2600 • Fax: (973) 593-6670  
 Web: [www.faradayfirealarms.com](http://www.faradayfirealarms.com)

**WARNING** - The information contained in this document is intended only as a summary and is subject to change without notice. The devices described in this document have specific instruction sheets which cover various technical, limitation and liability information. Copies of these instruction sheets and the General Product Warning and Limitations Document, which also contains important information, are provided with the product and are available from the Manufacturer. Information contained in these documents should be consulted before specifying or using the product. For further information or assistance concerning particular problems contact the Manufacturer.