

## Model VPS-200 Voice-Plus™ Voice Evacuation System

### Features

- Clean Dead-front Construction
- Digitally Recorded Automatic Evacuation Message (Up to 4 Minutes of Message Capacity)
- 100 Watt Bullet-Proof Amplifier (qty. 2)
- 25 or 70 VRMS Field Selectable
- 120 VAC Power Supply and Battery Charger
- Live Microphone Override of Message and Tone
- Analog Addressable Compatible
- High Reliability, No Maintenance and Fully Supervised
- Easy Installation and Operation
- Natural Sound Recordings
- Built in Alarm and Alert Signals
- Up to 4 Minute Message Capacity
- Works with 12VDC or 24VDC Fire Alarm Panels
- Works with Analog/Addressable and Microprocessor based Fire Alarm Panels
- Three Minute Message Restart on Microphone Key
- 24 Hour Backup with four 12V 7Ahr Batteries
- Made in the USA
-  UL, NYMEA & CSFM listed

### Description

The VPS-200 panel provides 200W of speaker power respectively. Speaker zones can be configured for general alarm or alarm by zone operation as required.

Digital message repeater, microphone, 120 VAC power supply and battery charger are all built in.

Faraday voice evacuation panels can be configured for Churches, Restaurants, MovieTheaters, Auditoriums and High Rise buildings.

The VPS-200 panel is an attractive surface or semi-flush mounted back box, with a hinged and key locked door. Cabinet dimensions are: 14-1/2" (W) x 27" (H) x 4" (D).

### Engineering Specifications

The voice evacuation system shall be Faraday VPS-200 or approved equal.

The voice evacuation system shall provide 200 Watts of signal and voice power, and shall be UL listed. All speaker circuits shall be field selectable



**VPS-200 With Keylocked Door Removed**

for 25 or 70 Vrms operation and shall be power limited.

The voice evacuation system shall be micro-processor based, and shall contain an integral microphone, audio amplifier, tone generator and digital message repeater.

A 120 VAC power supply and battery charger for standby batteries shall be included.

The voice evacuation message/signal shall be broadcast until the FACP is reset, or until fire emergency personnel interrupt the broadcast with a manual page. Remote paging microphone(s) will be supported through a supervised circuit.

## Specifications

### Primary Power (per module)

VP-100: 120VAC @ 2A

### 24 VDC Battery Power (per module)

VP-100: 0.18A Standby, 2.5A Alarm

### Output (per module)

VP-100: 100 Watts @ 25/70 VRMS, Tone and Voice

### Backbox Dimensions

14-1/2" (W) x 27" (H) x 4" (D)

## Ordering Information

Model	Description	Part No.
VPS-200	200W w/digital message repeater, power supply and microphone	500-649143FA
VPS-200/8Z	same as above w/8 speaker circuits	500-649144FA
VPS-200/12Z	same as above w/12 speaker circuits	500-649145FA
VPS-200/16Z	same as above w/16 speaker circuits	500-649146FA
<b>Accessories</b>		
VP-4Z	Four zone splitter	500-649147FA
VP-2ZA	Class "A" module	500-647148FA
VP-RM	Remote microphone	500-649149FA
VP-SC	Supervisory card	500-649150FA
VP-RSI	Serial interface	500-649151FA
VP-BA	Backup card	500-649152FA

## Typical Wiring

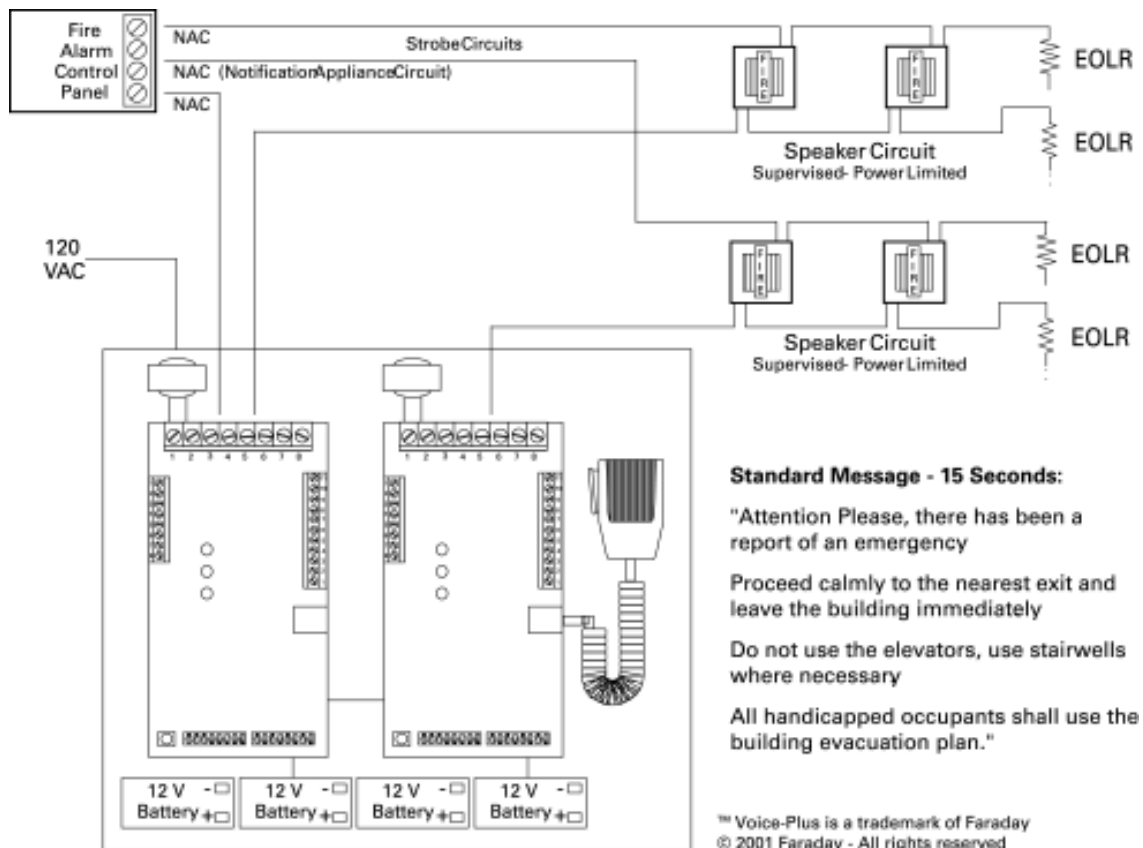

Siemens Building Technologies, Inc.  
 8 Fernwood Road • Florham Park, NJ 07932  
 Tel: (973) 593-2600 • Fax: (973) 593-6670  
 Web: www.faradayfirealarms.com

**WARNING** - The information contained in this document is intended only as a summary and is subject to change without notice. The devices described in this document have specific instruction sheets which cover various technical, limitation and liability information. Copies of these instruction sheets and the General Product Warning and Limitations Document, which also contains important information, are provided with the product and are available from the Manufacturer. Information contained in these documents should be consulted before specifying or using the product. For further information or assistance concerning particular problems contact the Manufacturer.